

P27.6
0917 EN



COMPACT P27.6



Compact P27.6

Merlo has developed a new high-performance compact telehandler. Compactness, lifting capacity, traction, comfort and high-level safety are the special features of the Merlo P27.6.

With a boom which extends to 6 metres in height for a lifted load of 2.7 tonnes, the P27.6 has the same modular cab as its big brothers, offering astounding space and visibility - unique in its category. With a top speed of 40 km/h (54,6kW model) and the option of being registered as an on-road agricultural tractor, the P27.6 handler is unrivalled in its class, and is the undisputed leader on the market.

- ✓ Maximum speed 40 km/h (54,6kW model): unique in its class
- ✓ Type-approval as an on-road agricultural tractor (optional)
- ✓ 5,9 metre booms: superior to the front loaders in height, speed and productivity
- ✓ Hydrostatic transmission with continuous variation from 0 to 40 km/h without torque interruption
- ✓ Two levels of torque and power
- ✓ Largest cab in its category: 1010 mm
- ✓ Maximum visibility in every direction

1. Joystick
2. Reverse shuttle
3. New display
4. New air conditioning system
5. Inching-control pedal
6. Curved windscreen
7. Drawer for storing objects

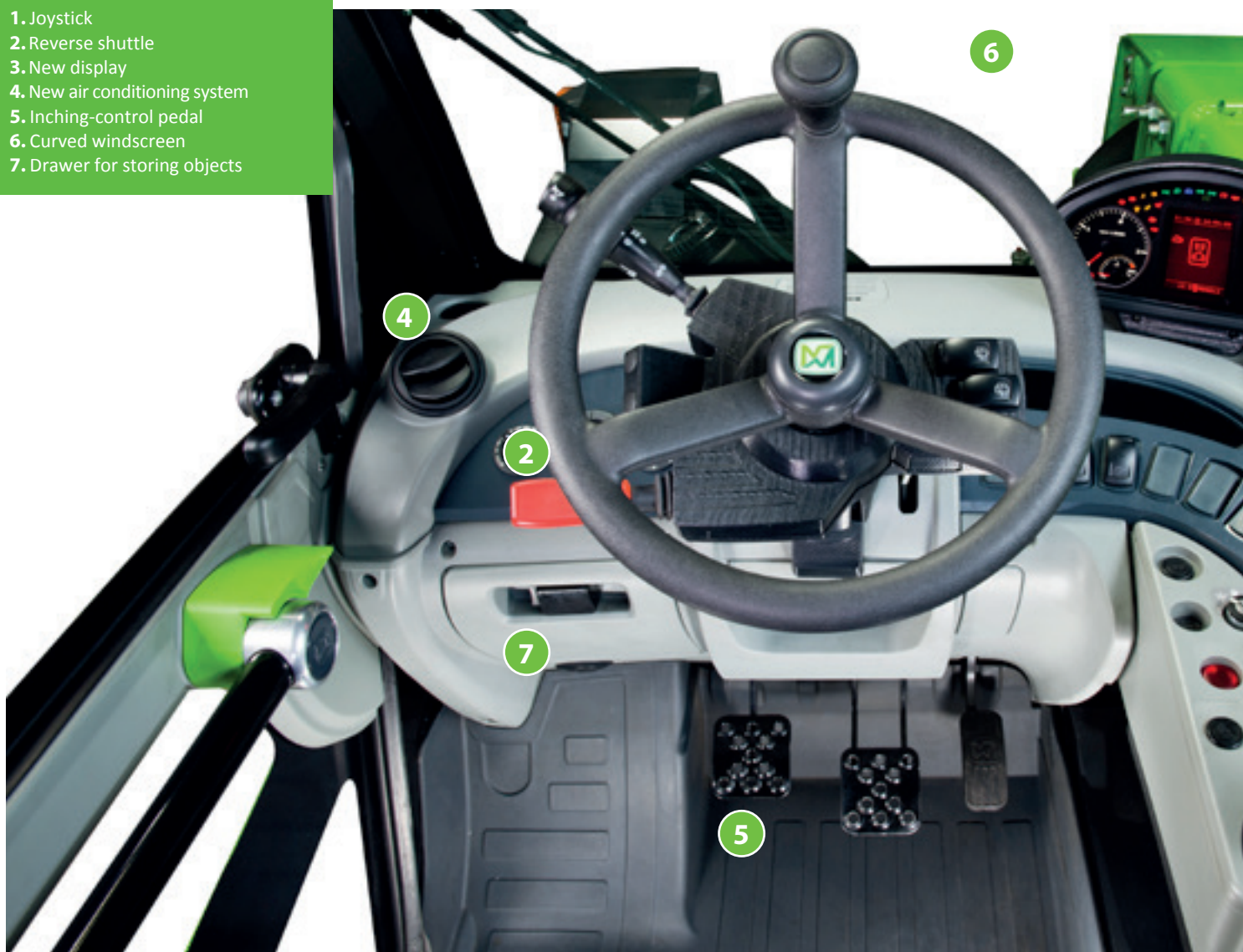



Cab



The P27.6 has the same modular cab as its big brothers, offering astounding space and visibility - unique in its category.

- ✓ The cab is the largest in its category: 1,010 mm of effective inside width and a window surface area measuring an amazing 4.3 m² for unrivalled visibility
- ✓ New modular cab as standard: pressurised (in conformity with ISO 10263-3 standards)
- ✓ The largest cab in its category: an advantage that also means that this model can be type-approved as an agricultural tractor
- ✓ Structure in line with ROPS and Level II FOPS international standards
- ✓ High visibility roof: being able to see the boom and the load at all times is fundamental for safety at work
- ✓ Reverse shuttle at steering wheel command: intuitive function at the operator's fingertips, improving manoeuvring safety and agility while maintaining full control of the steering wheel
- ✓ New analogue/digital control panel: clear, reliable and convenient
- ✓ Door opens by 180° with a separate small upper window: improved air circulation, visibility and direct contact with those working outside is guaranteed

Engine and transmission

At Merlo, our designers have adopted technologically-advanced diesel engines, evolved hydrostatic transmissions and axles equipped with dry disc brakes that help reduce power absorption. Electronic diesel engine/transmission management helps to optimise performance and minimise energy expenditure.

- ✓ Two power levels and two torque levels: 54,6 kW x 265 Nm and 36 kW x 170 Nm
- ✓ Advanced transmission command: excellent breakaway from standstill, fluid progression, optimisation of cycle times and fuel consumption
- ✓ Engines comply with anti-pollution standards with DOC (Diesel Oxidation Catalyst) and without DPF: streamlined maintenance and fewer worries for the operator
- ✓ New tapered bonnet: better visibility for improved safety
- ✓ Hydraulic gear pump: 94 l/min at 210 bar (for Plus and Top models) with optimal simultaneous control of all movements
- ✓ Maximum speed of 40 km/h (Plus and Top): the only model in its category which offers this, along with the option for type-approval as an agricultural tractor

ENGINES

Kubota V2607 Tier 3
36,5kW/50HP. Max torque 170
Nm at 1600 rpm.

Kubota V3307 DI Tier 4 Interim
3,4 l, 54,6kW/74,3HP. Max
torque 265 Nm at 1500 rpm.



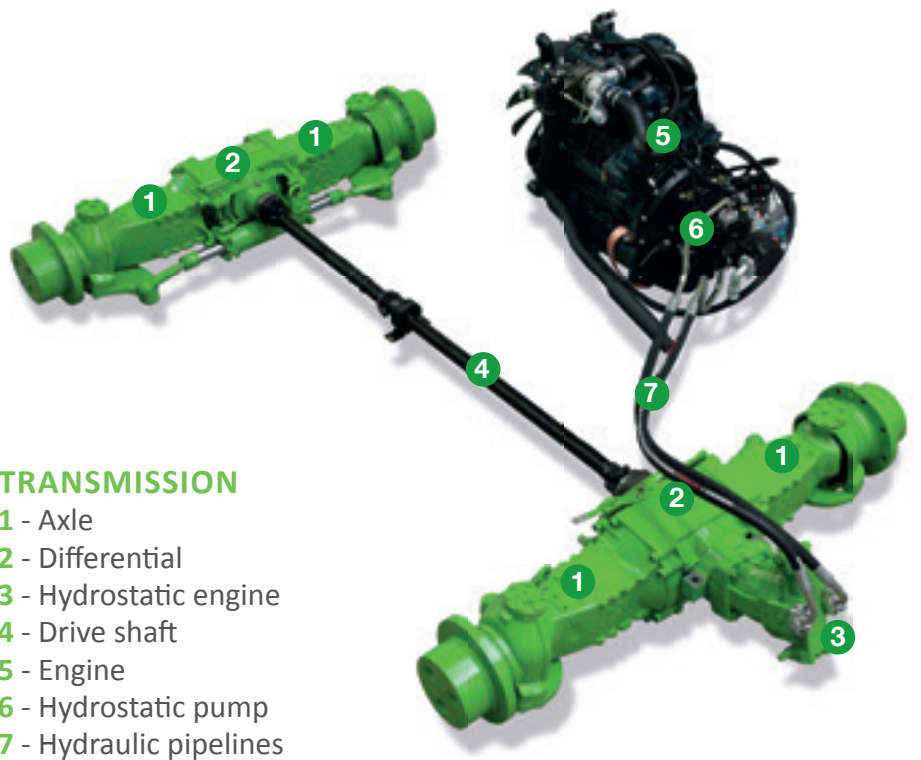

TRANSMISSION

- 1 - Axle
- 2 - Differential
- 3 - Hydrostatic engine
- 4 - Drive shaft
- 5 - Engine
- 6 - Hydrostatic pump
- 7 - Hydraulic pipelines



Axles

Merlo personally designs and produces most of the components that make up its telehandlers. The axles are an integral part of every design, and are conceived and sized for better integration with the main components of the machine.

- ✓ Axles designed and integrated into the design: maximum performance and excellent versatility thanks to the two torque levels available
- ✓ Planetary reducers: low centre of gravity, maximum reliability and high traction
- ✓ Maximum steering angle
- ✓ Three steering modes: front wheels, coordinated turning and sideways crab for easy handling and efficiency while working
- ✓ Four-wheel drive is always engaged: maximum traction in all conditions
- ✓ Integral servo-braking: acts on all four wheels for maximum safety in all working environments
- ✓ Parking brake: activates when the engine is turned off or, when the engine is on, from the cab
- ✓ Optional lock: for optimal disengagement on difficult terrain

THREE STEERING MODES

FRONT WHEEL STEERING



FOUR WHEEL COORDINATED STEERING



CRAB STEERING



TOWING

- ✓ The only machine in its category with type-approval as an agricultural tractor
- ✓ Towing hooks type-approved for agricultural use and as operating machines.
- ✓ A hydraulic outlet available for powering the trailer jacks
- ✓ A 7-pole electric socket supplies power to the trailer lights

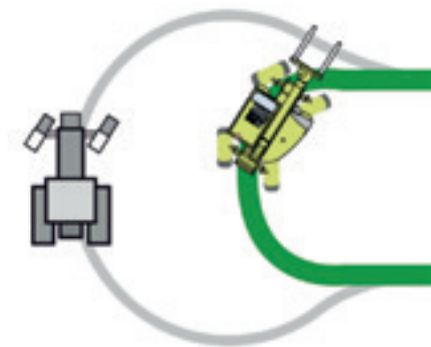

The optimal steering capacity and three steering modes allow for superb manoeuvrability and ease of use in all terrain conditions



Boom

The Merlo designers have created a sturdy, compact and light telescopic boom which has become the industry standard for design, load capacity and speed in the execution of work. The structural-type steel chosen for the boom is welded along the neutral bending axle, for a boom that stays straight regardless of extension and load conditions. Components such as pipes and cables are placed inside of the boom, ensuring that the external bodywork remains clean and free from obstructions caused by these components. The ZM2 equipment-holder carriage allows you to hook up any Merlo equipment. The hydraulic equipment locking is performed from the cab, while all hydraulic and electrical connections are quick-release.

- ✓ Lightweight yet strong for higher effective loads
- ✓ Two-section boom: maximum lifting height of 5,9 metres for matchless multi-function performance
- ✓ Protected hydraulic/electrical components
- ✓ ZM2 carriage: to ensure interchangeability with Merlo attachments already purchased by the operator, and for even better versatility
- ✓ Tac-Lock: replacement of tools from the driver's seat for greater comfort and safety
- ✓ Hydraulic/electrical connections: power supply to equipment for maximum versatility
- ✓ Anti-overturn system: automatically prevents high-risk movements in full observance of the EN15000 standard

The equipment carrier carriage is fitted with a Tac-Lock hydraulic locking system, which ensures the rapid replacement of tools whilst providing maximum operating comfort



Technical information

The Merlo P27.6 compact handler is a high-profile professional system which completes the extensive range of Merlo equipment, offering high levels of performance even in confined spaces. It's not a small handler - it's a big handler in a compact package.

PERFORMANCE AND FEATURES	P27.6	P27.6 PLUS	P27.6 TOP
Total unladen mass, with forks (kg)	4850	4850	4850
Maximum capacity (kg)	2700	2700	2700
Lifting height (m)	5,9	5,9	5,9
Maximum reach (m)	3,3	3,3	3,3
Maximum operating height (m)	4,6	4,6	4,6
Maximum operating reach (m)	1,2	1,2	1,2
Capacity at maximum height (kg)	1800	1800	1800
Capacity at maximum reach (kg)	1000	1000	1000
Turbo motor (displacement/cylinders)	2.6/4	3.3/4	3.3/4
Tier 4 Interim engine power (kW/HP)	36,5/50*	54,6/74,3	54,6/74,3
Maximum speed (km/h)	25	40	40
BSS hydro-pneumatic boom suspension	○	○	○
Fuel tank (l)	70	70	70
Hydraulic gear pump (bar-l/min)	210/75	210/94	210/94
Hydraulic oil tank (l)	70	70	70
FOPS (ISO 3449) and ROPS (ISO 3471) cab	●	●	●
Electro-mechanical joystick command on/off	●	●	●
Tac-Lock attachment locking	●	●	●
Hydrostatic transmission	●	●	●
Finger-Touch	●	●	●
Pedal-operated inching control	●	●	●
Permanent four-wheel drive	●	●	●
Four-wheel steering	●	●	●
Standard tyres	12-16.5"	12-16.5"	12-16.5"
Type approval as an agricultural tractor	○	○	○
Towing capacity (kg)	-	3100	4000

*Tier 3. ● As standard. ○ On request.

P27.6 DIMENSIONS			
A (mm)	3910	H (mm)	1840
B (mm)	820	M (mm)	1010
C (mm)	2450	P (mm)	1950
D (mm)	640	R (mm)	3370
E (mm)	3495	S (mm)	4200
F (mm)	270		

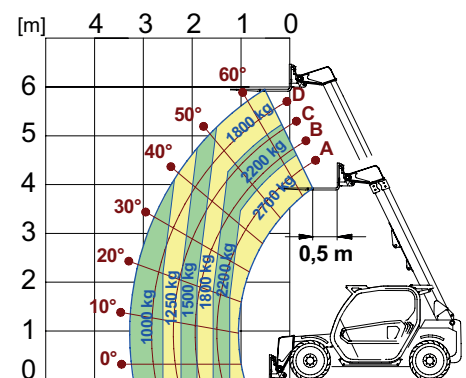
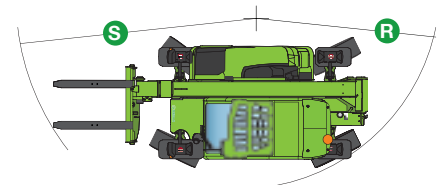
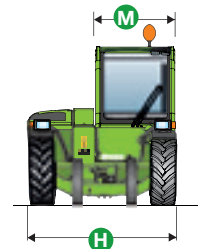
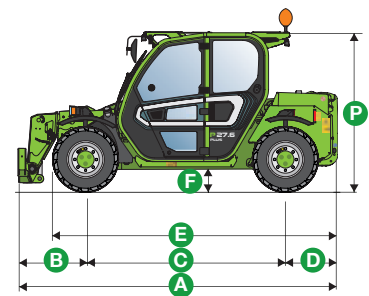

EN 1459/B



Attachments

Merlo has adopted a number simple yet effective guidelines to manage the product evolution process. Every last detail is studied and designed in the Group's factories - from conception to implementation. This simple rule also applies to our attachments, the operating tools used with our handlers - the fruit of the extensive experience gained by Merlo's expert technicians over time, through creating a broad and effective range of tools categorised according to type and operating capacity.

The P27.6 model uses original Merlo attachments, specifically designed for this machine. This standard allows Merlo to implement tested and interchangeable production attachments for targeted uses, in order to facilitate work and reduce the time taken to complete an operation.

3 POINT FORK



MANURE FORK WITH GRAB

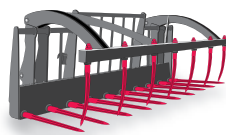

CALIPER FOR WRAPPED BALES

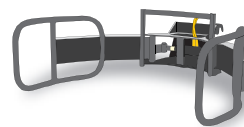

DOUBLE CALIPER WITH GRAB FOR BALES

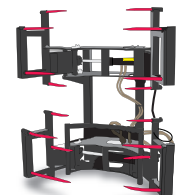

FLY JIB

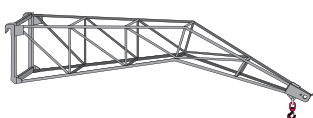

4X1 LOADER

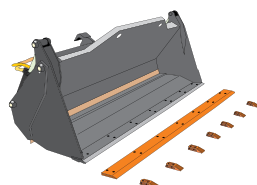

LIFTING BOOM



DIGGING BUCKET

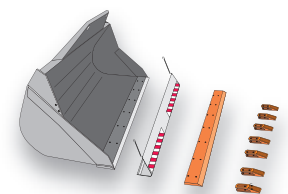

Merlo Group

The Merlo brand has always been synonymous with advanced technology in the telehandler field and the history of the company, which dates back to 1964, is distinguished by experience based on determination and passion. The development of complex products, from the idea to the result, from design to sales, means being able to propose orientations of the most competitive markets.

The outcome of our efforts are compact, easy to handle telehandlers ensuring incomparable operating performance, comfort, efficiency and safety.

At Agritechnica 2013, three important awards were received that clearly demonstrate the technological and innovative superiority of our products:

- ✓ Turbofarmer 42.7 Hybrid: Gold Medal for innovation at Agritechnica.
- ✓ Turbofarmer II: Machine of the year 2014 in the “handling and logistics” category.
- ✓ Multifarmer: Selected as a “milestone” in agriculture.

At Sima 2015, the new Medium Duty and Compact Turbofarmer modular range was crowned Machine of the Year 2015 in the handling and logistics sector.

Merlo's factories in San Defendente di Cervasca (Cuneo)

1. Merlo SpA main offices
2. Final assembly lines
3. Lines for assembling components and cabs
4. Moulding of technopolymers
5. Automated storage and shipping centre
6. Shipping centre for machines and attachments
7. Final quality control
8. Technological centre
9. Iron and steel centre and structural assembly lines
10. 3M attachments
11. CFRM (Training & Research Centre)





Merlo in figures



- > 1,100 employees
- Overall surface area of 300,000 m² of which 220,000 m² are indoors
- 90% of turnover generated by exports
- 600 dealers all over the world
- 8% of turnover invested in Research & Development
- 60 manufacturing robots



New automated, high-precision, dual-robotics centre



Compact P27.6

The data, features and illustrations contained in this document are only for indicative purposes only, and are not binding. Merlo Spa pursues a policy of continual research and development, and as such, our products may feature characteristics that differ from those described or may be subject to modification without prior notice. The products illustrated may include optional equipment.



MERLO S.P.A.

Via Nazionale, 9 - 12010 S. Defendente di Cervasca - Cuneo - Italia

Tel. +39 0171 614111 - Fax +39 0171 684101

www.merlo.com - info@merlo.com

P276EN 0917